

PICTORIAL VIEW
REFERENCE ONLY

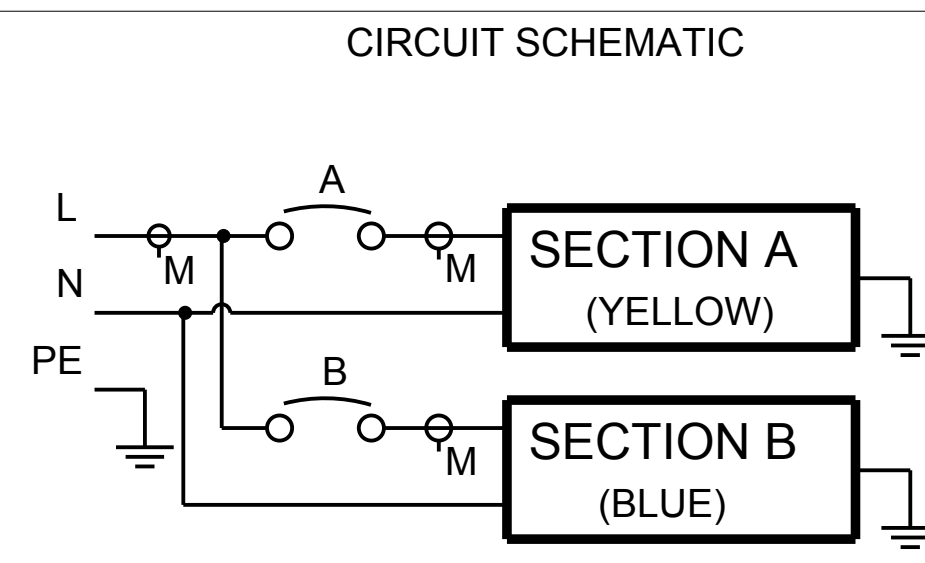

EMIH06		G3 METERED INPUT	
FUNCTIONALITY	INPUT	OUTPUT	ENVIRONMENTAL
CURRENT POWER AND ENERGY METERING FOR INPUT AND BRANCH	IEC 60309-2 32A 230V 2P+E 3.0M 4.0MM HO5 POWER CORD	(12) IEC 60320 C13 GRIP (4) IEC 60320 C19 GRIP	0 TO 60 °C
MECHANICAL	INPUT RATING	OUTPUT RATING	CERTIFICATIONS
LENGTH: 127 MM WIDTH: 444.5 MM DEPTH: 87.2 MM ALUMINIUM CHASSIS, BLACK	1PHASE L+N+PE 100/230v 32A	200-240V, 10A PER C13, 16A PER C19 16A MAX PER SECTION	CE, CB
CIRCUIT BREAKERS	FILTER AND SPIKE/SURGE	ACCESSORIES	CONFIGURATION
(2) 16A 1-POLE	NONE	STANDARD KSP013 - 2U INSTALLATION AND NETWORK KIT OPTIONAL EMP001 - ENVIRONMENTAL PROBE	EMI3CHJFDB21AM

01 ASSY PART NUMBER CORRECTION, WAS: EMI3CCJFADB21AM		29.04.2016	CW	MB
REV	MODIFICATION	DATE	DESIGNER	VERIF
EAT-ON HEINEMANN PRODUCTS		VUE/VIEW EUROPE: 1/2	ECHELLE / SCALE: 1/2	N° MAG: EMIH06
CH-1345 LE LIEU SWITZERLAND		DESSEINE LE / DRAWN THE: 17.03.2016	PAR / BY: G.McD.	VERIFIE PAR / VERIFIED BY: M.B.
NIVEAU DU CERTIFICAT DE SOUMISSION REQUIS / SAMPLES APPROVAL PROCESS REPORT: X		DIMENSIONS AND TOLERANCES IN MILLIMETERS		
DESIGNATION	EPDU MI 2U (309 32A 1P)C13x12:C19x4	SK-78219-Y1	01	
COTES A CONTROLER / INSPECTION DIMENSIONS: XX.XX	COTES FONCTIONNELLES / FUNCTIONAL DIMENSIONS: # XX.XX	NUMERO DU PLAN / PLAN NUMBER		
Ce document est propriété de Eaton Industries Manufacturing GmbH. Duplication interdite sans autorisation. This document is Eaton Industries Manufacturing GmbH property. Duplication forbidden without authorization.				