

SKU DETAILS

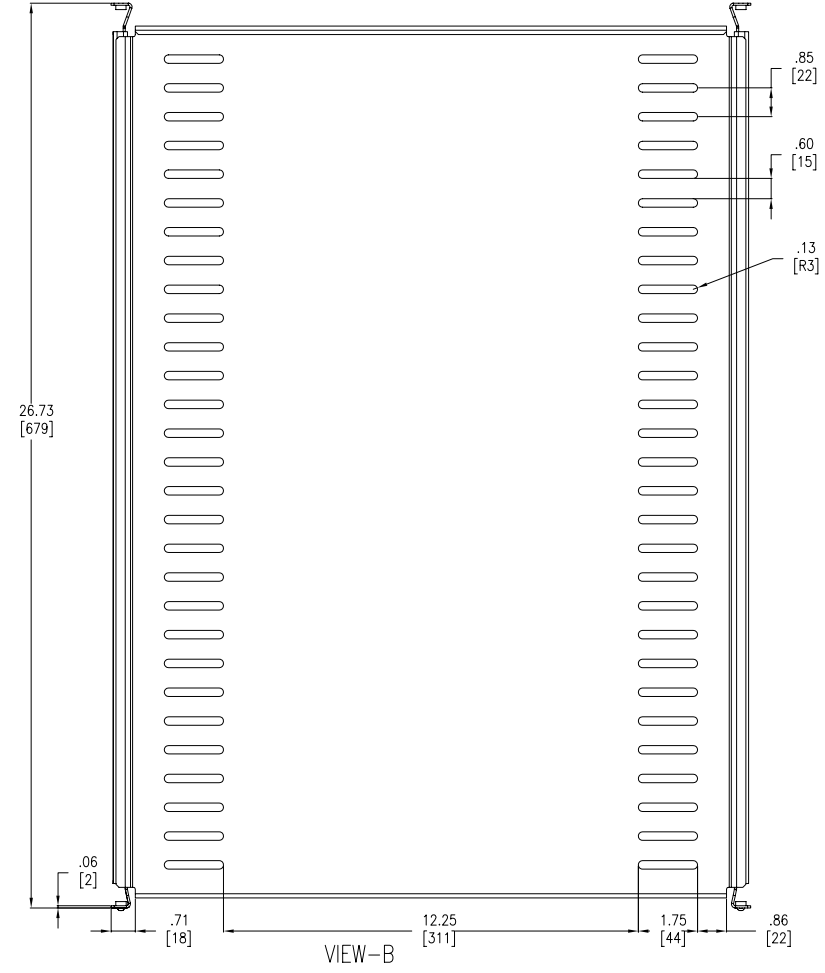

APPLICATION DETAILS

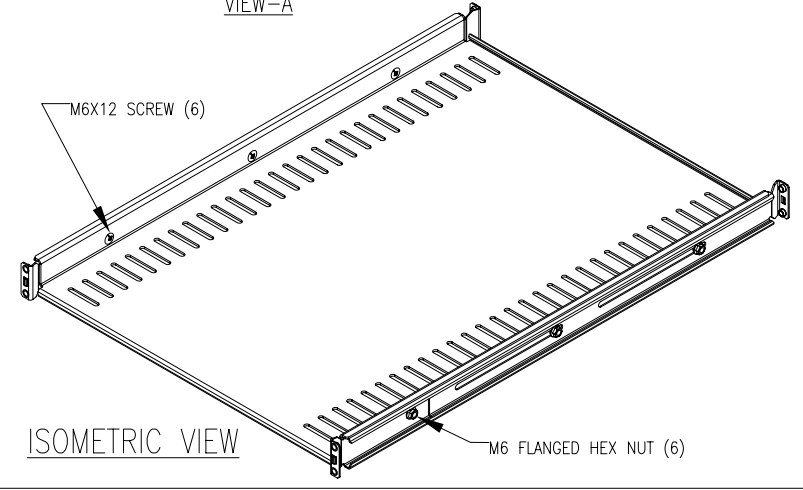
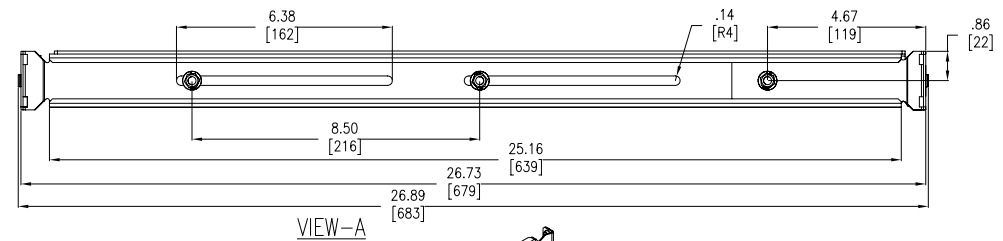
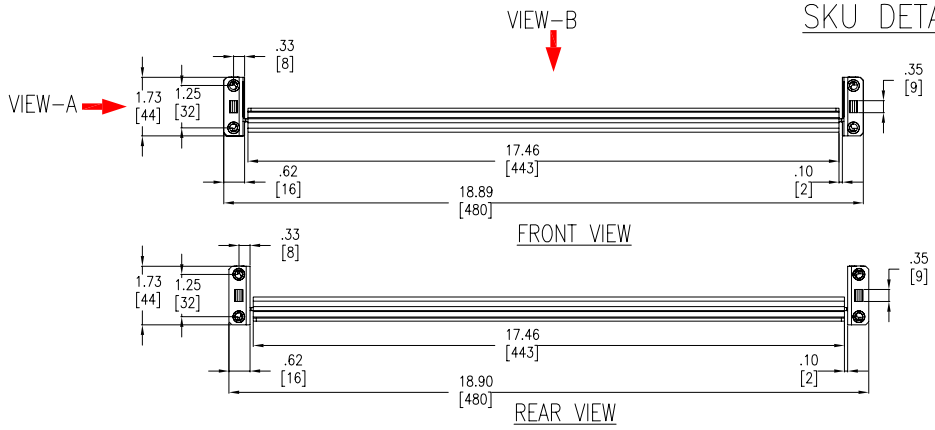
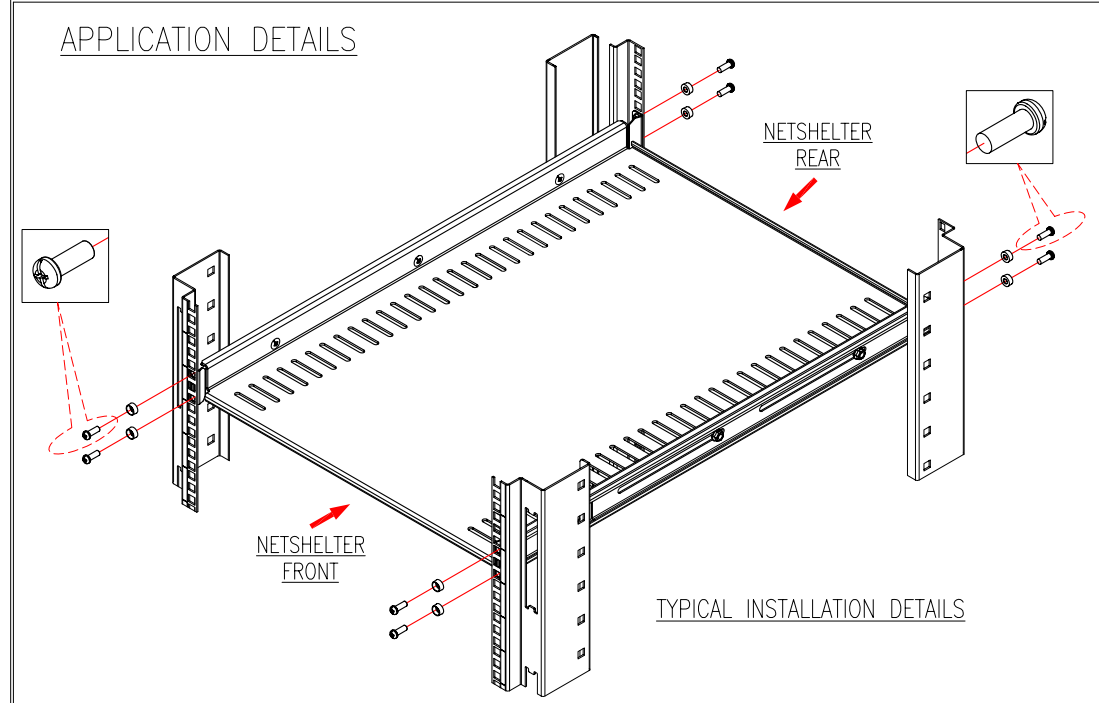

- NOTES:
1. INSTALLATION MUST COMPLY WITH ALL APPLICABLE NATIONAL AND LOCAL CODES.
 2. PLEASE REFER TO APC PRODUCT MANUAL FOR DETAILS.
 3. ALL DIMENSIONS ARE IN INCHES [MILLIMETERS].
 4. EACH SKU OF AR8122BLK INCLUDES (8)SCREWS M6X16, (8)CUP WASHERS M6.
 5. WEIGHT OF ONE UNIT IS 18 LBS [8.18 kg].

THIS DRAWING AND SPECIFICATIONS HEREIN ARE THE PROPERTY OF AMERICAN POWER CONVERSION AND SHALL NOT BE COPIED, REPRODUCED OR USED IN WHOLE OR IN PART, AS THE BASIS FOR THE MANUFACTURE OR SALE OF ITEMS WITHOUT WRITTEN PERMISSION FROM APC. THIS DRAWING IS BASED UPON LATEST AVAILABLE INFORMATION AND IS SUBJECT TO CHANGE WITHOUT NOTICE.



TITLE: FIXED SHELF 250lbs/114kg BLACK MAIN MECHANICAL

PROJECT: SUBMITTAL DRAWINGS SHEET 1 OF 1

DWG NO:	AR8122BLK	REV.	0
DRAWN:	BALAMURUGAN	05-MAR-08	ANGLE PROJECTION
ENGINEER:	M.UHRHAN/B.OLIVER	05-MAR-08	N.A
APPROVED:	B.SHERIDAN/E.SILVA/C.LARSEN/S.WACH	05-MAR-08	