

44.320

Addit dual monitor hygiene screen – monitor 32

Offering more protection within the workspace, the Addit dual monitor hygiene screen creates a safer division between you and whomever is on the other side of your monitors. The screens are easily mounted on your monitor arm using the same VESA connections that keep your monitors in place. The flexible connector strip makes sure that the two halves of the screen become one large perfectly aligned protective surface. Because of that, it's always in the right position for the protection of you and your colleagues. Ideal for dual screen set-ups, toolbars and sit-stand desks. What if this solution is temporary?

Become part of the Dataflex return program and we'll give the product a second life. We will make sure that we rethink and repurpose the product or recycle it in a safe, reliable and eco-friendly manner. In exchange for returning the product you will receive a voucher for your next purchase with Dataflex.

- Offers more protection within the workspace
- Easy to add to your existing set-up
- Fitted between VESA mounts of monitor arm and monitors
- Unique mounting slots makes horizontal adjustment possible
- Ideal for dual monitor set-ups and sit-stand desks
- Eligible for the Dataflex return program (24 months after purchase)
- Suitable for monitors with cable connectors on the side/bottom
- Also functions as memo board
- VESA MIS-D 100 x 100 mm compatible
- Dimensions: 800 x 677 x 3mm per screen - Width: 1600mm total
- Suitable for screens from 22" to 27"
- Material: 100% recyclable Acrylic (PMMA)
- Weight: 3.8 kg (2 x 1.9kg)
- Included: fasteners, Allen key, flexible H-profile to connect screens
- Easier installation with our VESA quick-release mounts

addit

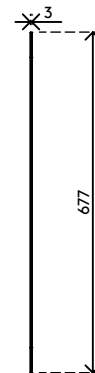
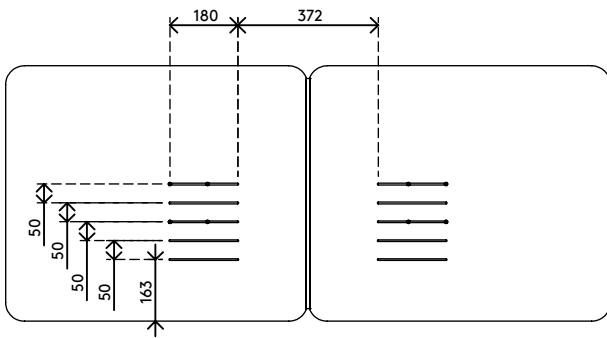
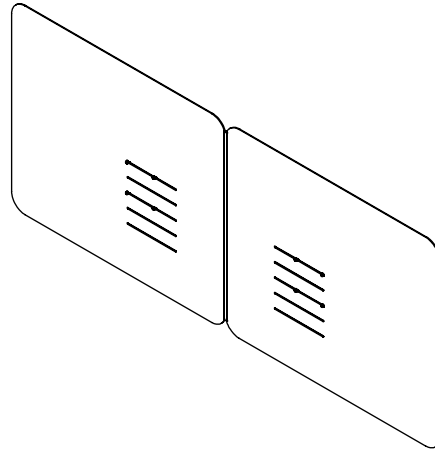
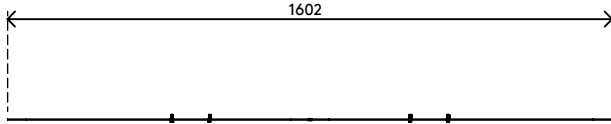

Addit dual monitor hygiene screen – monitor 32

2020/06/17

44.320

 845 x 720 x 15 mm

 1 pcs

 clear acrylic

 4,6 kg

 805410443207