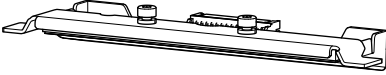

Installation Instructions for the ZT231 Printer

Read these instructions thoroughly before installing this kit.

Parts List

Before proceeding, verify that your kit contains the following items. To reorder specific parts, navigate to zebra.com/parts, and select your printer model.

Printhead		Qty 1
-----------	--	-------

Tools Needed

- Zebra preventative maintenance kit (p/n 47362 or p/n 105950-035 for a multipack) or a lint-free cloth dipped in 99.7% isopropyl alcohol
- Antistatic wrist strap and mat

Prepare for Installation



NOTE: Retain all parts removed during disassembly, unless otherwise directed.



CAUTION—ESD: Observe proper electrostatic safety precautions when handling static-sensitive components such as circuit boards and printheads.

1. Turn off the printer and disconnect it from the power source.
2. Disconnect all data cables.
3. Open the media cover.

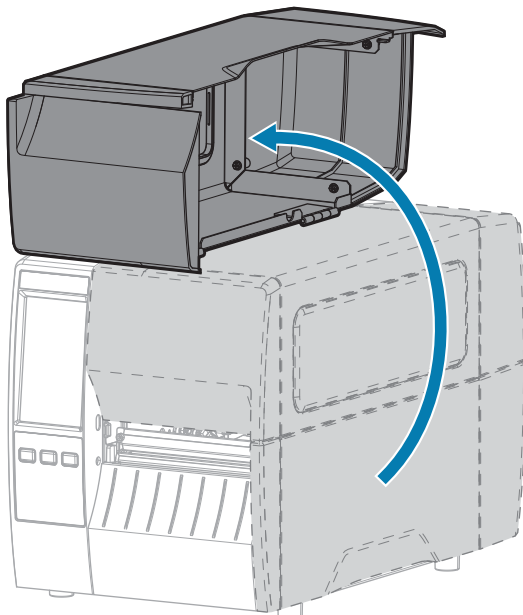

4. Remove media and ribbon (if used).

Replace the Printhead



CAUTION—HOT SURFACE: The printhead may be hot and could cause severe burns. Allow the printhead to cool.

1. Connect yourself to an antistatic device.
2. Slide the printhead latch forward to the unlocked position.

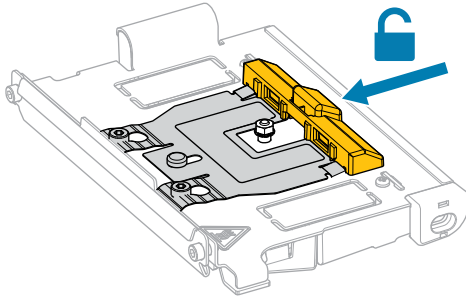

3. Release the printhead assembly.

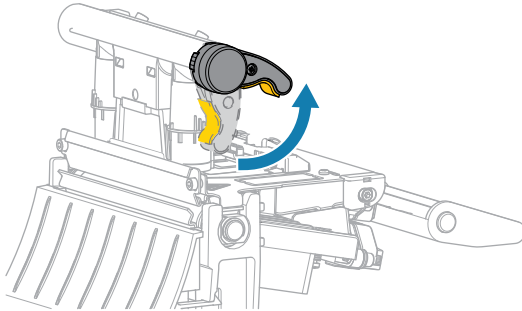

As the printhead lever rotates upward, the printhead assembly pivots upward.

4. Pull the printhead from the upper print mechanism.

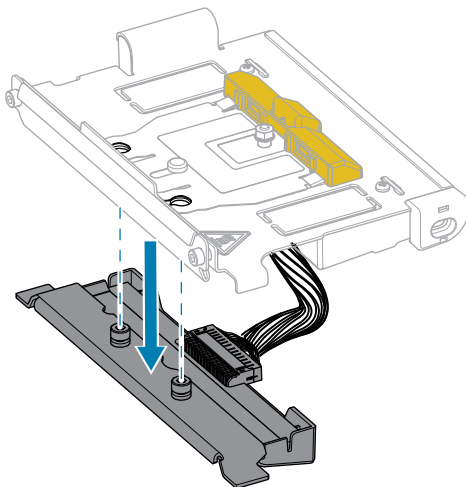

-
5. Disconnect the printhead cable from the old printhead.

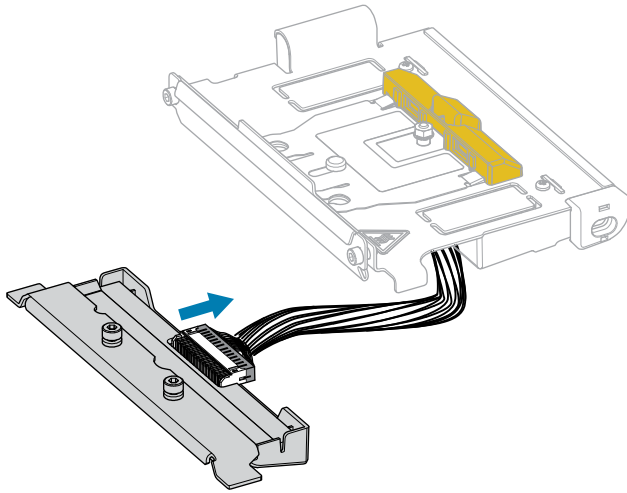

6. Connect the printhead cable to the new printhead.

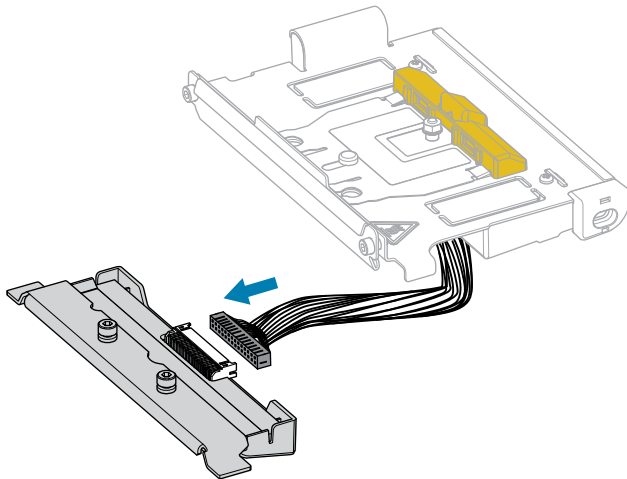

7. Slide the printhead into the print mechanism, assuring that the printhead locking posts go into the printhead latch holes.

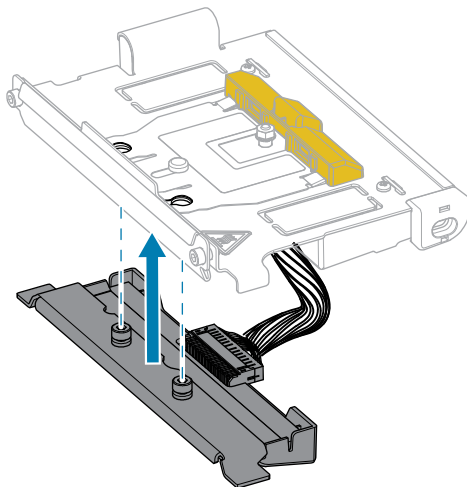

8. While holding the printhead in place, slide the printhead latch back to the locked position.

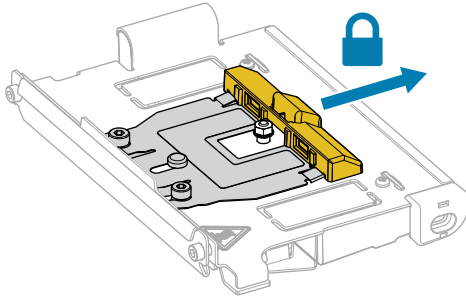

9. Clean the printhead.

- a) Using the swab from the Preventive Maintenance Kit (p/n 47362 or p/n 105950-035 for a multipack), wipe the print elements (gray strip) from end to end. In place of this kit, use a lint-free cloth dipped in 99.7% isopropyl alcohol.
- b) Allow the solvent to evaporate.

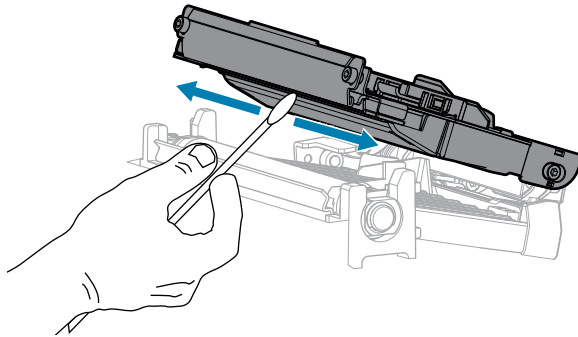

Resume Printer Operation

1. Reinstall media and ribbon (if used).
2. Close the printhead assembly.

-
3. Close the media cover.

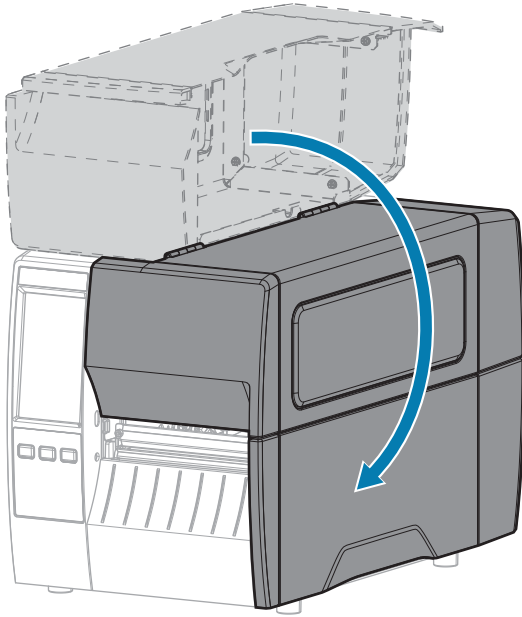

4. Reconnect the AC power cord and interface cables.
5. Turn on the printer power.